



Hand Pallet Truck DF Series

Features:

- The oil pump body is made by way of welding the prefabricated parts together first, then machining the welded body.
- Ergonomic Large Rubber handle with three control lever.
- Special lowering valve to control the trucks durable.
- Chrome piston and ram for smooth operation and prevents excessive wear on the pump & seal.
- Excellent turning angle of 180 degree facilities.
- Number of pump strokes-10. Lift height per stroke:11mm.
- Spray plastic painting surface.
- Option: Nylon wheel, polyurethane wheel, rubber wheel. Single fork roller or tandem fork roller.
- Remark: Special size for width and length can be made according to customer's requirement.

1KG=2.2LB 1INCH=25.4MM

Model			DF20		DF25		DF30	
Capacity	Q	kg	2000		2500		3000	
Min.fork height	h	mm	85	75	85	75	85	75
Max.fork height	h1	mm	200	190	200	190	200	190
Steering wheel		mm	Φ200x50	Φ180x50	Φ200x50	Φ180x50	Φ200x50	Φ180x50
Load roller Single		mm	Φ80x93	Φ74x93	Φ80x93	Φ74x93	Φ80x93	Φ74x93
		mm	Φ80x70	Φ74x70	Φ80x70	Φ74x70	Φ80x70	Φ74x70
Size of fork	e*s	mm	160x60					
Width overall forks	B	mm	450/520/550/685					
Fork length	I	mm	800/900/1000/1100/1150/1220					



Model DF hoisting jack

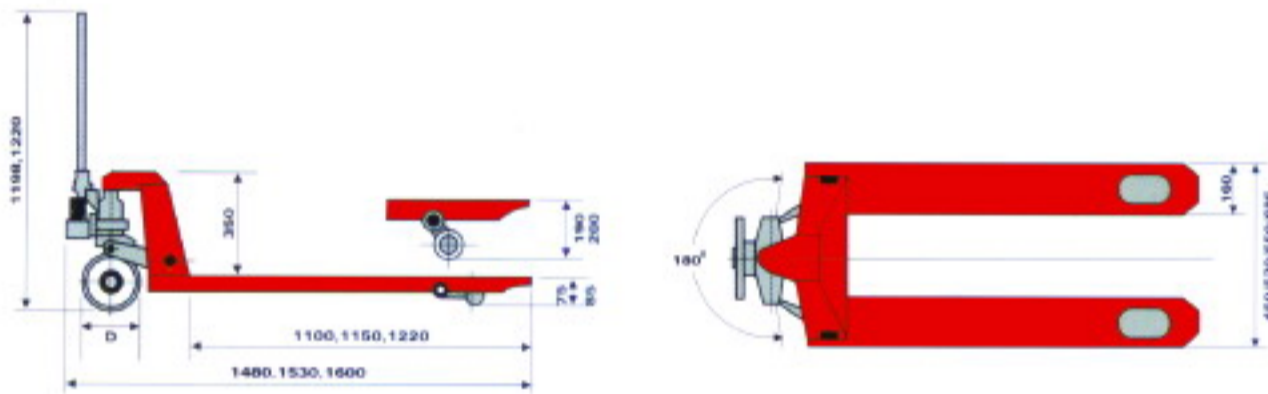

Hand Pallet Truck NA Series

Feature:

- GS/TUV approved in Germany.
- 3 year warranty period.
- Lighter weight easier rolling design.
- Fully rebuildable pump unit with overload valve.
- Hard chrome-plated lift ram and pump piston.
- Entry & exit ramps for prolonged trouble-free use.
- High strength, one-piece tapered forks with precision size.
- 3 coats stoving-paint.
- Heavy duty ball bearings for lower maintenance.
- Highest quality seals and wipers.
- Easy to use 3-position control lever.
- Assemble instruction and parts book with (itemized prices) are supplied.

Options:

- For roller: single or tandem, Polyurethane or Nylon.
- Low-profile: Min. fork height 35mm.
- Galvanized steel pallet truck.
- Stainless steel pallet truck.
- Pallet truck with brake system.
- Pallet truck with scale.
- Over length and over width pallet trucks are available.
- OEM productions are acceptable.

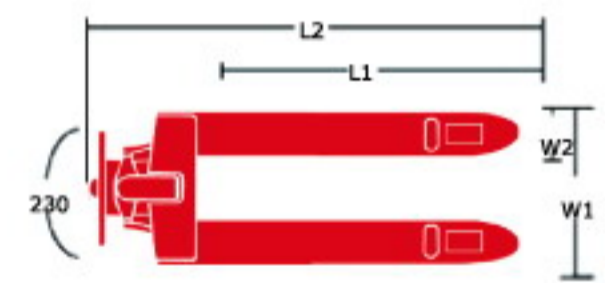
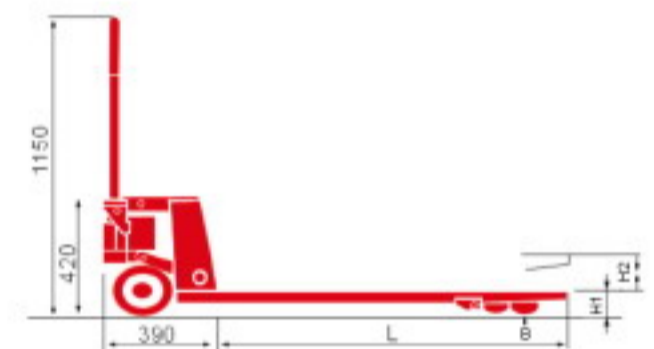

1KG=2.2LB 1INCH=25.4MM

Model		NA15/NA20/NA25/NA30		
Capacity	kg	1500/2000/2500/3000		
Max.Fork Height	H2	95/121/165/195/200		
Min.Fork Height	H1	35/51/65/75/80		
Fork Length	L1	810/980/1070/1150/1220		
Overall Length	L2	390 + L1		
Overall Fork Width	W1	460	520	685
Single Fork Width	W2	150		
Load Roller	B	Ø78x70/Ø78x100 Nylon/Polyurethane		
Steering Wheel	A	Ø200(Ø180) Nylon/Polyurethane/Rubber		
Net.Weight	kg	84	89	92
Quantities/20ft Container	pcs	180		174

Remark: 3500kg(NA35)/5000kg(NA50) available on request